

bitnet<sup>TM</sup>

**BNSFP1GMM Multi Mode 1.25G 850 550M  
LC DDM Fiber**



# Description:

The SFP transceivers are high-performance, cost-effective modules supporting data-rate of 1.25Gbps and 550m transmission distance with MMF. The transceiver consists of three sections: a VCSEL laser transmitter, a PIN photodiode integrated with a trans-impedance preamplifier (TIA) and MCU control unit. All modules satisfy class I laser safety requirements. The transceivers are compatible with SFP Multi-Source

Agreement (MSA) and SFF-8472. For further information, please refer to SFP MSA

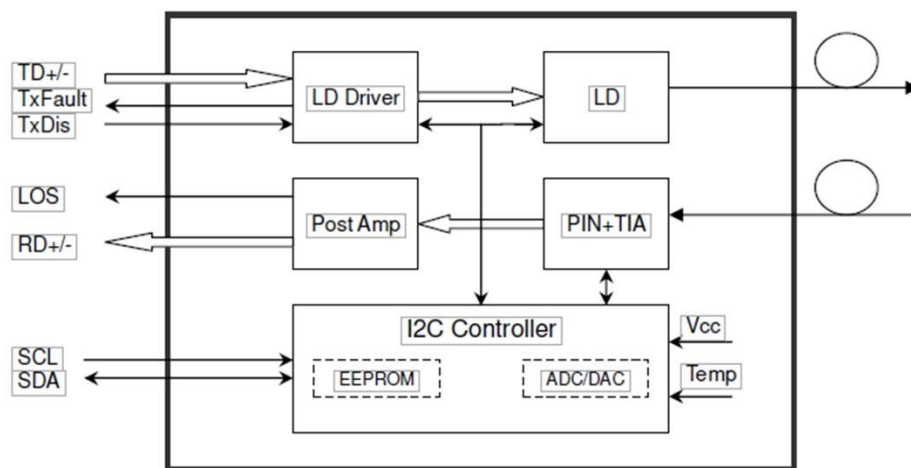

## Product Features:

- ☞ Data-rate of 1.25Gbps operation
- ☞ 850nm VCSEL laser and PIN photo detector
- ☞ Compliant with SFP MSA and SFF-8472 with duplex LC receptacle
- ☞ Digital Diagnostic Monitoring:
  - ☞ Internal Calibration or External Calibration
- ☞ 550m transmission with 50/125 $\mu$ m MMF
- ☞ 300m transmission with 62.5/125 $\mu$ m MMF
- ☞ Compatible with RoHS
- ☞ +3.3V single power supply
- ☞ Operating case temperature: Standard : 0 to +70°C
- ☞ Industrial:-40 to +85°C

## Applications:

- ☞ Gigabit Ethernet
- ☞ Fiber Channel
- ☞ Switch to Switch interface
- ☞ Switched backplane applications
- ☞ Router/Server interface
- ☞ Other optical transmission systems

## Absolute Maximum Ratings:

Parameter	Symbol	Min	Max	Unit
Supply Voltage	V <sub>cc</sub>	-0.5	4.5	V
Storage Temperature	T <sub>s</sub>	-40	+85	°C
Operating Humidity	-	5	85	%

## Operating Conditions:

Parameter		Symbol	Min	Typical	Max	Uni
Operating Case Temperature	Standard	T <sub>c</sub>	0		+70	°C
	Industrial		-40		+85	°C
Power Supply Voltage		V <sub>cc</sub>	3.13	3.3	3.47	V
Power Supply Current		I <sub>cc</sub>			300	mA
Data Rate				1.25		Gbps

## Optical and Electrical Characteristics:

Parameter	Symbol	Min	Typical	Max	Unit	Notes
<b>Transmitter</b>						
Centre Wavelength	$\lambda_c$	830	850	860	nm	
Spectral Width (-20dB)	$\Delta\lambda$			0.85	nm	
Side Mode	Pout	-10		-3	dB	1
Average Output Power	ER	9			dB	
Extinction Ratio	tr/ta			0.26	ns	
Optical Rise/Fall Time (20%~80%)	VIN	400		1800	mV	2
Data Input Swing Differential	ZIN	90	100	110	$\Omega$	
TX Disable	Disable		2.0		Vcc	V
	Enable		0		0.8	V
TX Fault	Fault		2.0		Vcc	V
	Normal		0		0.8	V
<b>Receiver</b>						
Centre Wavelength	$\lambda_c$	770		860	nm	
Receiver Sensitivity				-18	dB	3
Receiver Overload		-3			dB	3
LOS De-Assert	LOS			-20	dB	

LOS Assert	LOSA	-35			dB	
LOS Hysteresis		1		4	dB	
Data Output Swing Differential	Vout	370		1800	mV	4
LOS	High	2.0		Vcc	V	
	Low			0.8	V	

**Notes:**

1. The optical power is launched into MMF.
2. PECL input, internally AC-coupled and terminated.
3. Measured with a PRBS 27-1 test pattern @1250Mbps, BER  $\leq 1 \times 10^{-12}$ .
4. Internally AC-coupled

## Timing and Electrical:

Parameter	Symbol	Min	Typical	Max	Unit
Tx Disable Negate Time	t_on			1	ms
Tx Disable Assert Time	t_off			10	$\mu$ s

Time To Initialize, including Reset of Tx Fault	t_init			300	ms
Tx Fault Assert Time	t_fault			100	μs
Tx Disable To Reset	t_reset	10			μs
LOS Assert Time	t_loss_on			100	μs
LOS De-assert Time	t_loss_off			100	μs
Serial ID Clock Rate	f_serial_clock			400	KHz
MOD_DEF (0:2)-High	VH	2		Vcc	V
MOD_DEF (0:2)-Low	VL			0.8	V

## Diagnostics :

Parameter	Symbol	Min	Typical	Max
Temperature	0 to +70	°C	±3°C	Internal / External
	-20 to +85			
Voltage	3.0 to 3.6	V	±3%	Internal / External
Bias Current	0 to 100	mA	±10%	Internal / External

TX Power	-10 to -3	dBm	±3dB	Internal / External
RX Power	-22 to -3	dBm	±3dB	Internal / External

## Digital Diagnostic Memory Map:

The transceivers provide serial ID memory contents and diagnostic information about the present operating conditions by the 2-wire serial interface (SCL, SDA). The diagnostic information with internal calibration or external calibration all are implemented, including received power monitoring, transmitted power monitoring, bias current monitoring, supply voltage monitoring and temperature monitoring. The digital diagnostic memory map specific data field defines as following

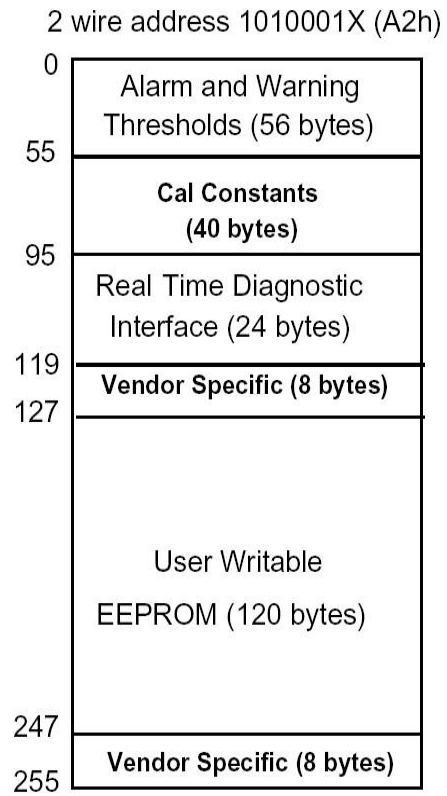
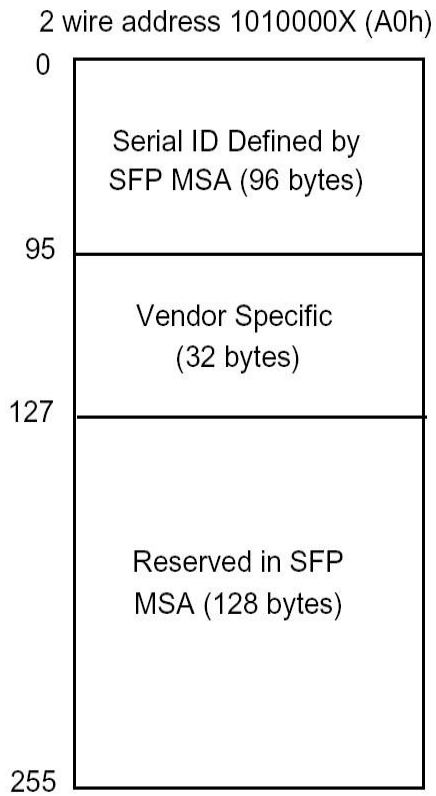

# Pin Definitions:

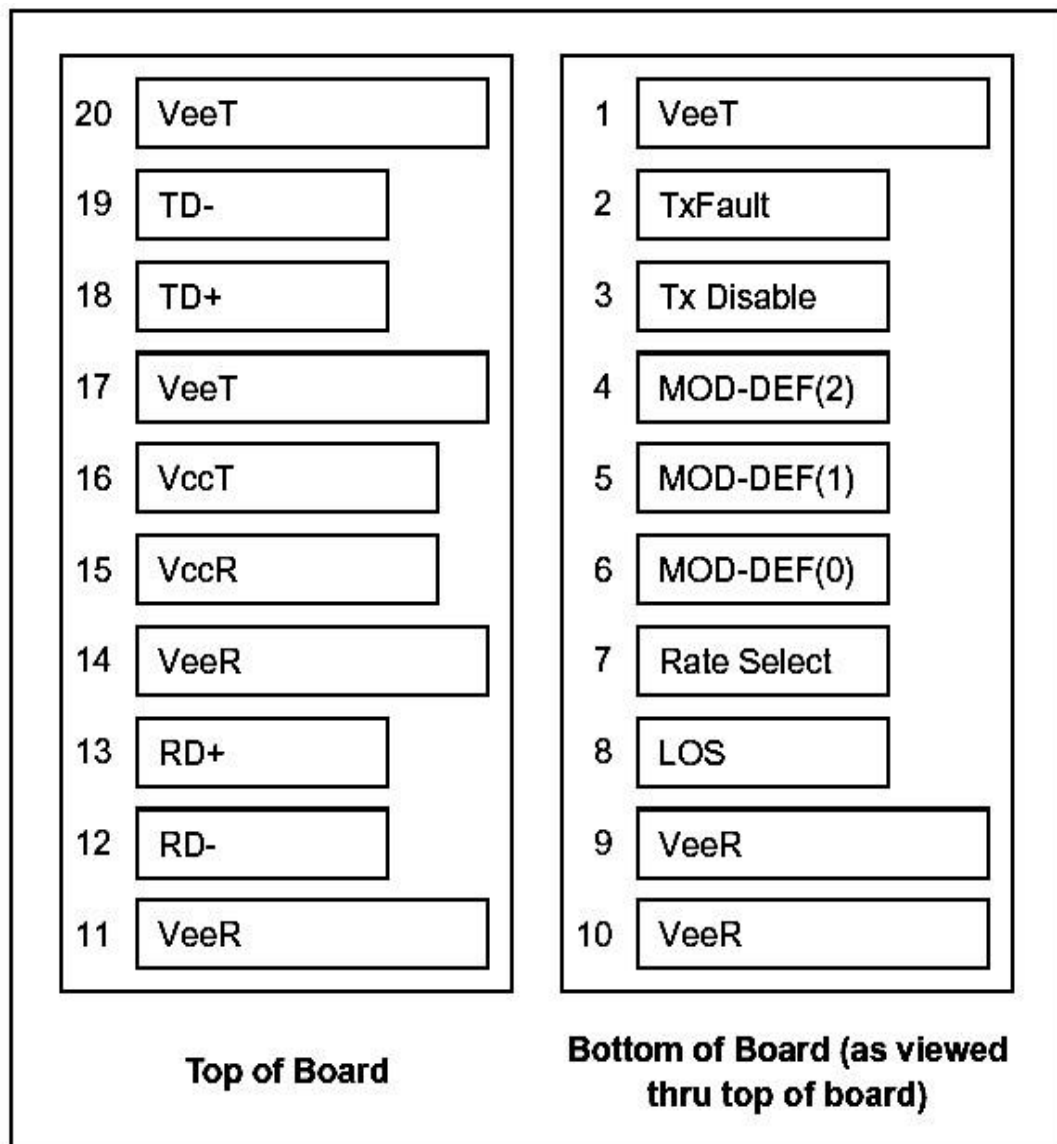

## PIN Descriptions:

Pin	Signal Name	Description	Plug Seq.	Notes
1	VEET	Transmitter Ground	1	
2	TX FAULT	Transmitter Fault Indication	3	Note 1
3	TX DISABLE	Transmitter Disable	3	Note 2
4	MOD_DEF(2)	SDA Serial Data Signal	3	Note 3
5	MOD_DEF(1)	SCL Serial Clock Signal	3	Note 3
6	MOD_DEF(0)	TTL Low	3	Note 3
7	Rate Select	Not Connected	3	
8	LOS	Loss of Signal	3	Note 4
9	VEER	Receiver ground	1	
10	VEER	Receiver ground	1	
11	VEER	Receiver ground	1	
12	RD-	Inv. Received Data Out	3	Note 5
13	RD+	Received Data Out	3	Note 5
14	VEER	Receiver ground	1	
15	VCCR	Receiver Power Supply	2	
16	VCCT	Transmitter Power Supply	2	
17	VEET	Transmitter Ground	1	
18	TD+	Transmit Data In	3	Note 6
19	TD-	Inv. Transmit Data In	3	Note 6

20	VEET	Transmitter Ground	1	
----	------	--------------------	---	--

**Notes:**

Plug Seq.: Pin engagement sequence during hot plugging.

1) TX Fault is an open collector output, which should be pulled up with a 4.7k~10kΩ resistor on the host board to a voltage between 2.0V and Vcc+0.3V. Logic 0 indicates normal operation; Logic 1 indicates a laser fault of some kind. In the low state, the output will be pulled to less than 0.8V.

2) TX Disable is an input that is used to shut down the transmitter optical output. It is pulled up within the module with a 4.7k~10kΩ resistor. Its states are:

- Low (0 to 0.8V): Transmitter on
- (>0.8V, < 2.0V): Undefined
- High (2.0 to 3.465V): Transmitter Disabled
- Open: Transmitter Disabled

3) Mod-Def 0, 1, 2. These are the module definition pins. They should be pulled up with a 4.7k~10kΩ resistor on the host board. The pull-up voltage shall be VccT or VccR. Mod-Def 0 is grounded by the module to indicate that the module is present Mod-Def 1 is the clock line of two wire serial interface for serial ID Mod-Def 2 is the data line of two wire serial interface for serial ID

4) LOS is an open collector output, which should be pulled up with a 4.7k~10kΩ resistor. Pull up voltage between 2.0V and Vcc+0.3V. Logic 1 indicates loss of signal; Logic 0 indicates normal operation. In the low state, the output will be pulled to less than 0.8V.

5) RD-/+: These are the differential receiver outputs. They are internally AC-coupled 100 differential lines which should be terminated with 100Ω (differential) at the user SERDES.

6) TD-/+: These are the differential transmitter inputs. They are internally AC-coupled, differential lines with 100Ω differential termination inside the module

# Recommended Interface Circuit:

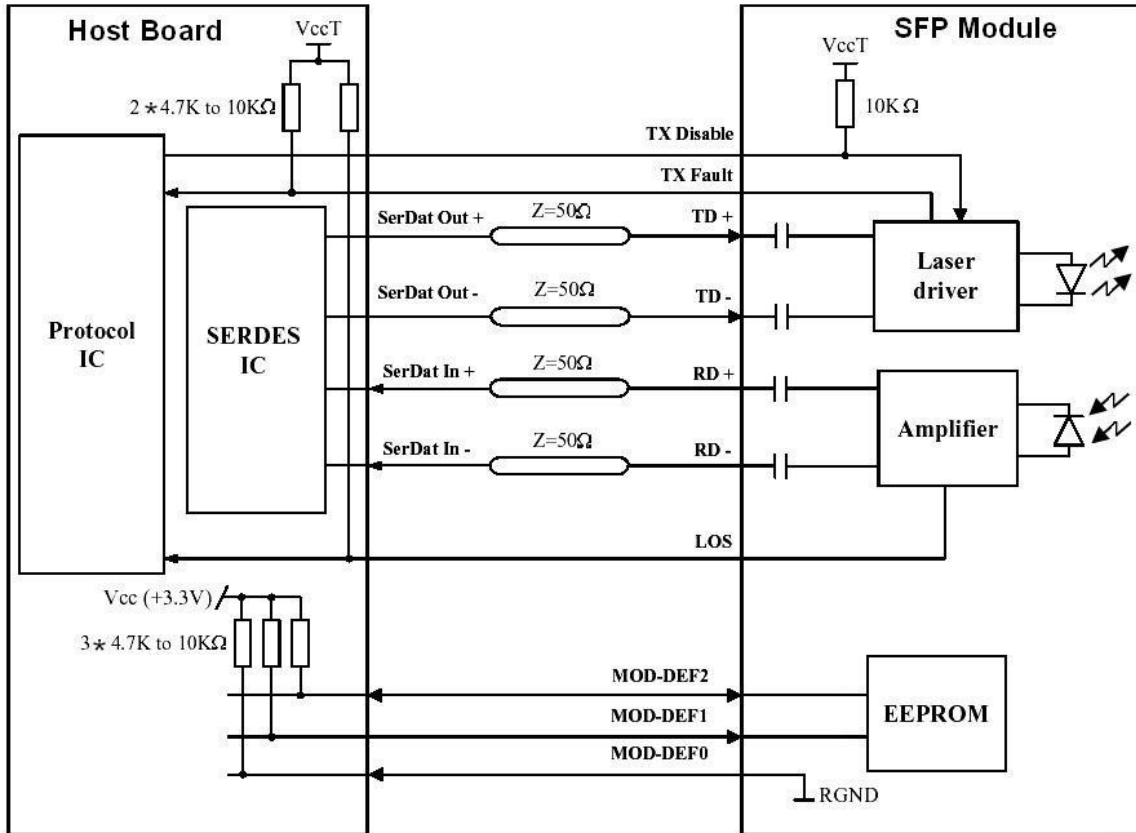

# Mechanical Dimensions:

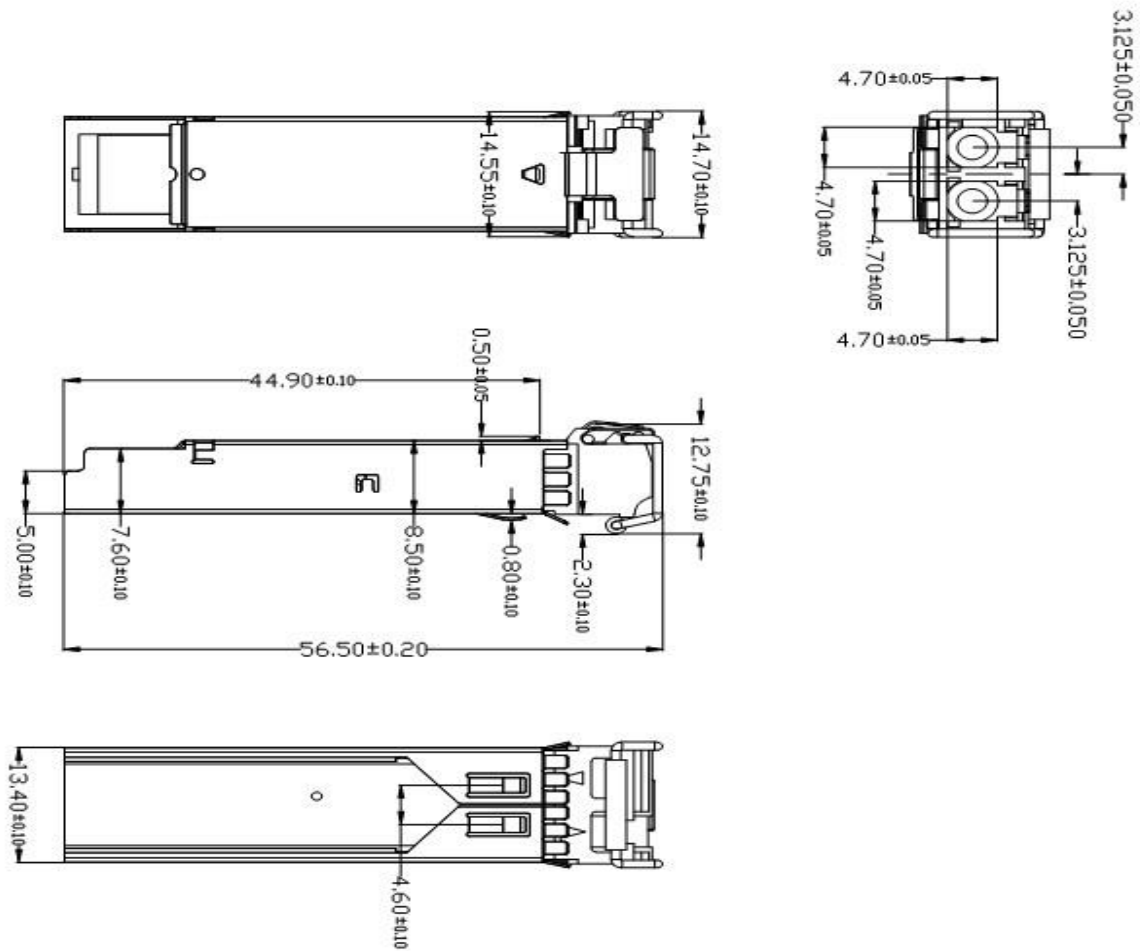

## ABOUT BITBOX:

Bitbox is a leading technology brand based in India, proudly contributing to the government's "Make in India" initiative and committed to promoting domestic manufacturing, innovation, and technological advancements in the country. With a vision to drive India's digital transformation, we focus on developing cutting-edge technology solutions. Leveraging a highly skilled workforce, state-of-the-art infrastructure, and strategic partnerships, the brand strives to provide world-class products and services that meet global standards.

